

# FXAIM04D-DW AI module

ControlNet™ FLEX I/O™ Thermocouple inputs : 7

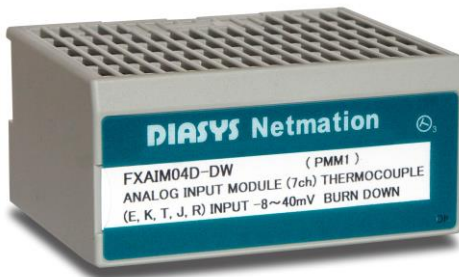

## ■ Outline

- \* Number of inputs: 7 (Thermocouple)
  - T,R,J,K,E type correspondence
  - -8 to 40 mV full scale
  - Detect underrange when disconnected
- \* Cold junction compensation RTD (Pt 100 Ω) input : 1
- \* AD converter duplicated
- \* FLEX I/O™ / ControlNet™ LAN compatible

\*ControlNet™ is ControlNet International's registered trademark.  
\*FLEX I/O™ is Rockwell Automation's registered trademark.

ITEM	SPECIFICATION
Number of inputs	7 (Thermocouple input) 1 (Cold junction compensation input)
Isolation	Individual
Input range	T : -200 to 400°C R : -50 to 1768°C J : -114 to 677°C K : -163 to 909°C E : -99 to 508°C RTD : -10 to 100°C
Resolution	16 bits
Input impedance	More than 5 MΩ
Data format	16 bits 2's complement
AD converter	Duplicated Selection system based on upper logics
Conversion type	Successive approximation
Conversion rate	5 μs/ch
Data refresh cycle	40 ms
Relative accuracy	±0.1% FSD
Temperature drift	Less than ±100 ppm/°C
Input filter	(1) Analog filter (2) Digital filter
Wire break detection	About 33.1 ms 0 ms, 50 ms, 100 ms, 500 ms (Program selectable, whole channels batch setting)
Self-diagnostic functions	Move to lower limit when break-down Watchdog timer Power supply voltage low Bus time-out
Indicator	LED × 1 2 modes Green (Normal) Red (Abnormal)
Compatible terminal bases	1794 - TB3/TB3S 1794 - TBN/TBNF
Dielectric strength	AC 500 V Between input terminal and FG (1 min.) Between input channels (1 min.)
Environmental conditions	(Operating) Temperature: 0 to 55°C Humidity: 5 to 95% RH (No condensation) (Storage) Temperature: -40 to 85°C Humidity: 5 to 95% RH (No condensation)
Power supply	DC 24 V ±10% / Less than 60 mA DC 5 V / Less than 80 mA (FLEX BUS)
Shock/Vibration	15 G / 2 G @ 10 to 500 Hz
Dimensions	75 mm (D) × 46 mm (H) × 94 mm (W)

This product uses technology licensed from Rockwell Automation Technologies, Inc.

# FXAIM04D-DW AI module

ControlNet™ FLEX I/O™ Thermocouple inputs : 7

\*ControlNet™ is ControlNet International's registered trademark.  
\*FLEX I/O™ is Rockwell Automation's registered trademark.

## FXAIM04D-DW block diagram

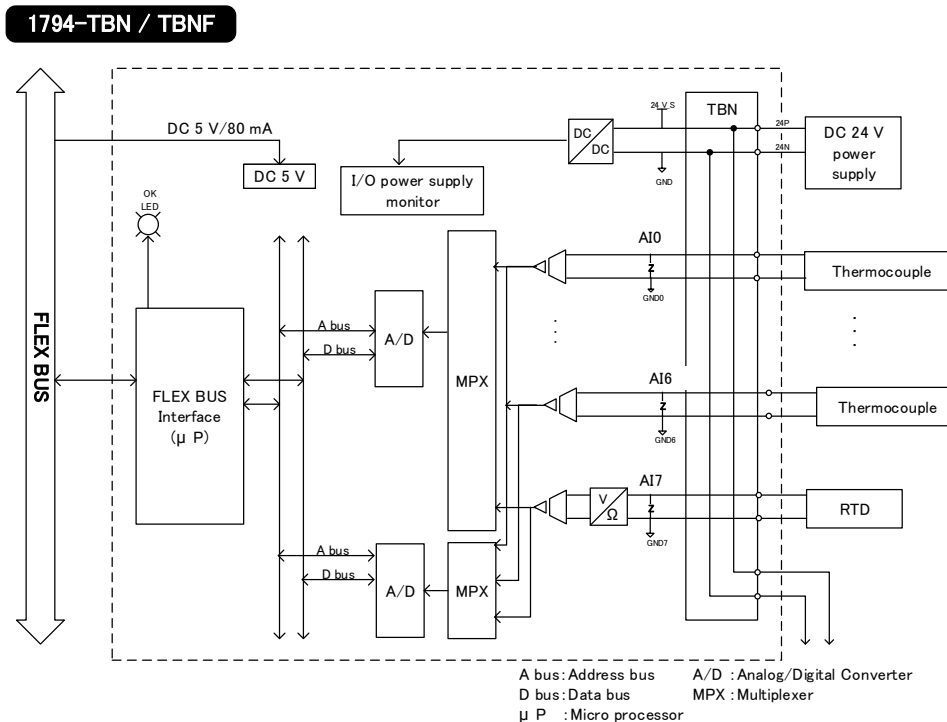
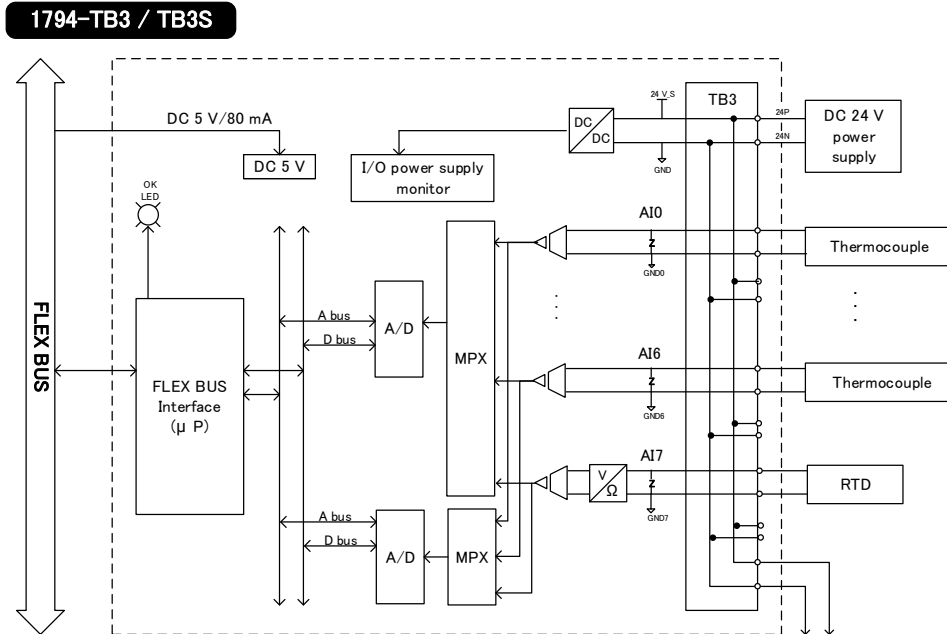

When using, please read the instruction manual attached to the product carefully and use it properly.

This catalog may not be distributed or reproduced in whole or in part without permission.

Please be aware that due to product improvements and modifications, the product description in this catalog may differ in certain respects from the actual product.

DIASYS Netmation/DIASYS Netmation4S is a registered trademark of Mitsubishi Heavy Industries, Ltd.

The service names and product names of other companies described in this catalog are the trademarks or registered trademarks of each company.