

RCK-FAN-N1/RCK-FAN-N2 Cooling fan unit

CPCHS21/CPCHS24 Cooling fan unit fan Two equipped



ITEM	SPECIFICATION
Rated voltage	DC 24 V
Rated current	0.19 A (per fan one)
Rated speed	2600 rpm
Maximum weight	2.9 Nm ³ /min
Expected lifespan	200,000 hours
Fan sensor	Open collector output (Normally Close output / 1 point per fan one)
Environmental conditions	(Operating) Temperature: -10 to 60°C Humidity: 20 to 85% RH (No condensation) (Storage) Temperature: -10 to 60°C Humidity: 20 to 85% RH (No condensation)

Summary

- * Compact PCI duplex CPU chassis
Cooling fan unit for CPCHS21/CPCHS24
- * Fan Two equipped (Fan one / 1 CPU slot)
- * Fan stop alarm output present
- * Expected lifespan 200,000 hours

*About the difference between RCK-FAN-N1 and RCK-FAN-N2

RCK-FAN-N1: The mounting metal fittings for the CPU chassis is located at the position of the intermediate in the depth direction of the chassis.

RCK-FAN-N2: The mounting metal fittings for the CPU chassis is located at the position of the front in the depth direction of the chassis.

Block diagram

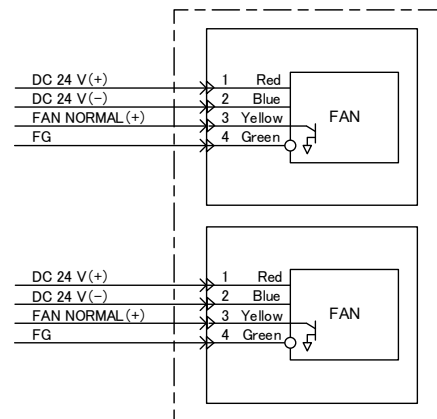

When using, please read the instruction manual attached to the product carefully and use it properly.

This catalog may not be distributed or reproduced in whole or in part without permission.

Please be aware that due to product improvements and modifications, the product description in this catalog may differ in certain respects from the actual product.

DIASYS Netmation/DIASYS Netmation4S is a registered trademark of Mitsubishi Heavy Industries, Ltd.

The service names and product names of other companies described in this catalog are the trademarks or registered trademarks of each company.