

LSEOS01-1 EOST module

LS communication Turbine overspeed trip function

■ Summary



* Terminal block input / output unit

-52 G ON Digital input	: 1
-Power supply output for speed sensor supply	: 1
-Rotational speed input	: 1
	1 to 12000 Hz 1 to 200 Vp-p
-EOST Digital output	: 2
-Rectification speed pulse output	: 2

* Indicator

-Display LED	: 4 RUN / STS / NSA / NSB
-Channel State LED	: 16 Ch 1 to Ch 16

* USB connector

: 1 (For maintenance communication mini-B)

* Module operating ambient temperature range : -5 to 60°C

■ Overview Specifications

ITEM	SPECIFICATION
52 G ON Digital input	DC 24 V × 1, minimum ON Current 2 mA
Power supply output for speed sensor supply	DC 24 V ±10% × 1
Rotational speed input	1 to 12000 Hz, 1 to 200 Vp-p, Resolution: 0.1 Hz × 1
EOST Digital output	Open collector output × 2, Maximum voltage DC 30 V, Maximum load current 0.1 A
Rectification speed pulse output	Maximum voltage DC 30 V × 2, Maximum load current 4 mA
Indicator	Display LED × 4: Run/ Status/ Network status A/ Network status B General purpose display LED × 16: Ch 1 to Ch 16 Arbitrarily set by internal logic
USB connector	For maintenance communication mini-B × 1
Self-diagnostic functions	Power voltage check, Clock abnormal check, Heartbeat check, CRC check
IDOL Implementation	Possible
Module Duplication	Unsupported
Dielectric strength	AC 1500 V Digital input / output terminal - PE Between AC 1350 V Rotation count input terminal - PE Between
Environmental conditions	Ambient temperature (Operating / Storage) -5 to 60°C Ambient humidity (Operating / Storage) 0 to 95% RH (No condensation)
Operating power supply	DC 24 V ±20% Dual power reception (The voltage supplied from the backplane)
Shock / Vibration	15 G 11 ms / 3.5 mm @5 Hz to 8.4 Hz, 1 G @8.4 Hz to 150 Hz
Dimensions	152.5 mm (D) x 94 mm (H) x 46 mm (W) (Except projection)

LSEOS01-1 EOST module

LS communication Turbine overspeed trip function

■Details Specifications

ITEM		SPECIFICATION		
I/O Input/output section	Ch 1: 52 G ON Digital input	Number of channels	1	
		Insulation method	Photocoupler insulation (Individual isolation)	
		Dielectric strength	AC 1500 V Digital input terminal - PE Between	
		Current range	ON current	DC 2 mA or more
			OFF current	Sense supply voltage: DC 24 V ±10% DC 1 mA or less
	Ch 4: Power supply output for speed sensor supply	Number of channels	1	
		Insulation method	Transformer insulation	
		Dielectric strength	AC 1350 V Sensor power supply output terminal - PE Between	
		Output voltage	DC 24 ±10%	
		Supply current limit	26 mA	
	Ch 5: Rotational speed input	Number of channels	1	
		Insulation method	Photocoupler insulation	
		Dielectric strength	AC 1350 V Rotation count input terminal - PE Between	
		Speed measurement range	1 to 12000 Hz (full scale)	
		Input voltage range	1 to 200 V _{p-p} Chopping Voltage: -18 to +18 V	
		Over speed trip setting range	800 to 11900 Hz	
		Resolution	0.1 Hz	
	Accuracy	±0.01% FS @20 to 200 V _{p-p}		
	Ch 6, Ch 7: EOST Digital output	Number of channels	2 (Open collector)	
		Insulation method	Photocoupler insulation (Individual isolation)	
		Dielectric strength	AC 1500 V Digital output terminal - PE Between	
		Contact maximum voltage	DC 30 V	
		Contact withstand current	100 mA	
		Leakage current at OFF	0.1 mA or less	
	Ch 8, Ch 9: Rectification speed pulse output	Number of channels	2	
		Insulation method	Photocoupler insulation (Individual isolation)	
		Dielectric strength	AC 1500 V Digital output terminal - PE Between	
		Contact rated voltage	DC 30 V	
Contact withstand current		4 mA		
Leakage current at OFF		0.1 mA or less		
Maximum residual voltage when ON	DC 1.0 V @4 mA			
Calculation cycle usable in DPS		10 msec or more		
Communication specification between IOA		Communication method , communication speed LVDS, 100 Mbps		
Self-diagnostic functions		Power voltage check (24 V, 17 V, 3.3 V, 1.2 V, Other) *Refer to block diagram Clock abnormal check (FPGA-MCU, FPGA-CPU) Heartbeat check (FPGA-MCU, FPGA-CPU) CRC check (FPGA-MCU)		
IDOL Implementation		Possible Supplement: IDOL is the logic description language used in DIASYS-UP, DIASYS-UP/V. The internal logic of this module is described in IDOL.		
Module Duplication		Unsupported		
Protective function (Backplane supply power protection)		Overvoltage protection, Overcurrent protection		
Indicator	Display LED	4: RUN (Run) /STS (Status) /NSA (Network status A) /NSB (Network status B)		
	General purpose display LED	16: Ch 1 to Ch 16 Arbitrarily set by internal logic		
Serial interface	For maintenance	1: USB Serial (USB mini-B connector)		
Hot swap		Possible		
Operating power supply		DC 24 V ±20% Dual power reception (The voltage supplied from the backplane)		
Environmental conditions	Module ambient temperature	(Operating / Storage) -5 to 60°C		
	Module ambient humidity	(Operating / Storage) 0 to 95% RH (No condensation)		
Vibration		3.5 mm @5 to 8.4 Hz 1 G @8.4 to 150 Hz		
Shock		15 G 11 ms		
Current consumption		180 mA or less		
Weight		0.19 kg		
Dimensions		152.5 mm (D) x 94 mm (H) x 46 mm (W) (Except projection)		
Standard/Directive		EN 61131-2:2007, RoHS		

About compliant module type

For compliant modules of this product, please refer to "Compliant backplane list (CGS-S9901-E-XX)".





For compliant modules of this product, please refer to "Compliant accessory connector list (CGS-S9902-E-XX)".

LSEOS01-1 EOST module

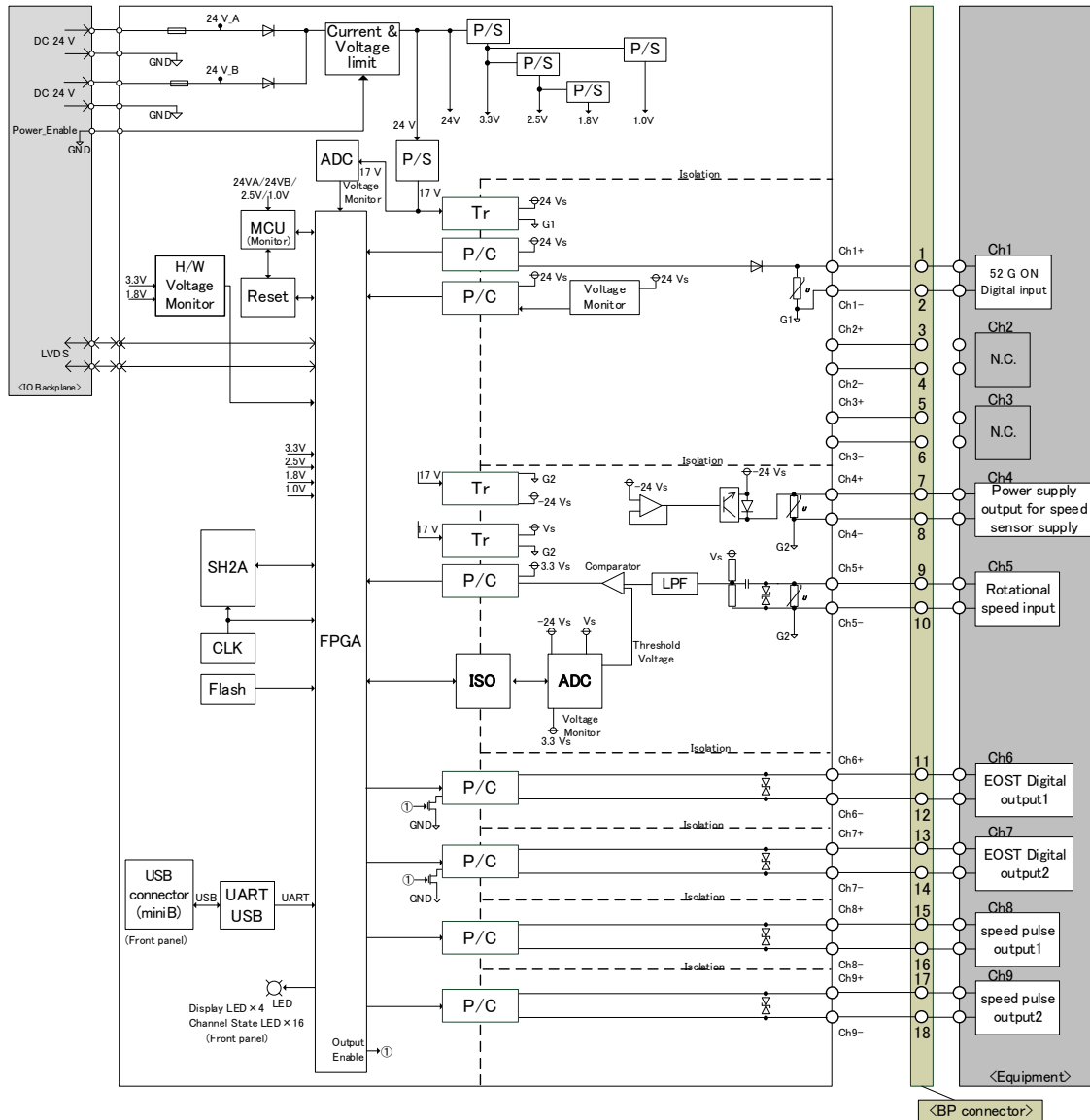
LS communication Turbine overspeed trip function

■ Block diagram



P/S	: Power supply	MCU	: Micro control unit
SH2A	: Renesas SH-2A micro processor	FPGA	: Field programmable gate array
CLK	: Clock generation circuit	LED	: Light emitting diode
ISO	: Digital isolator	ADC	: Analog digital converter
LPF	: Low pass filter	GND, G1, G2	: Ground
LVDS	: Low Voltage Differential Signaling	BP	: Backplane
P/C	: Photo Coupler	Tr	: Transformer
N.C.	: No Connection	Flash	: Flash ROM
	: Varistor	UART	: Universal Asynchronous Receiver Transmitter
	: Fuse		: Resistor
	: Bidirectional diode		: Diode

When using, please read the instruction manual attached to the product carefully and use it properly.

This catalog may not be distributed or reproduced in whole or in part without permission.

Please be aware that due to product improvements and modifications, the product description in this catalog may differ in certain respects from the actual product.

DIASYS Netmation/DIASYS Netmation4S is a registered trademark of Mitsubishi Heavy Industries, Ltd.

The service names and product names of other companies described in this catalog are the trademarks or registered trademarks of each company.