

LSIOB02-2 I/O module backplane

Redundant Supports 2 modules

■ Summary



- * I/O module backplane : Supports 2 modules
 - * Power Supply : DC 24 V (Supply from LSADB01 backplane)
 - * Characteristic : Redundant correspondence type
(Butt connection between the IO terminal connector)
-

LSIOB02-2 I/O module backplane

Redundant Supports 2 modules

Specifications

ITEM		SPECIFICATION
Power supply	Power supply	DC 24 V \pm 20% (Supply from LSADB01 backplane)
	Input method	Power receive of the independent 2 lines, Butt connection between the IO terminal connector
Backplane connector (Field I/O connector parts)	Number of connectors	2
	Power supply	400 V DC
	Rated current	3 A
I/O module contact connector	Number of connectors	2
Dielectric strength		Between terminal block - SELV 24 V power supplies: DC 3250 V 60 sec Between terminal block - PE: DC 3250 V 60 sec
Environmental conditions	Module ambient Temperature	(Operating) -5 to 60°C (Storage) -40 to 85°C
	Module ambient humidity	(Operating / Storage) Less than 95% RH (No condensation)
Vibration		3.5 mm @5 to 8.4 Hz 1 G @8.4 to 150 Hz
Shock		15 G 11 ms
Indicator		Single/Redundant key
Current consumption		1.0 mA
Weight		0.7 kg
Dimensions		42.5 mm (D) x 159.4 mm (H) x 228.4 mm (W) (Except projection)
Standard/Directive		EN 61131-2, RoHS

About compliant module type

For compliant modules of this product, please refer to "Compliant backplane list (CGS-S9901-E-XX)".

Precaution:

- This backplane can not be used as a single configuration of the IO module.
- IO backplane connection of each other, you and up to three-stage connection.

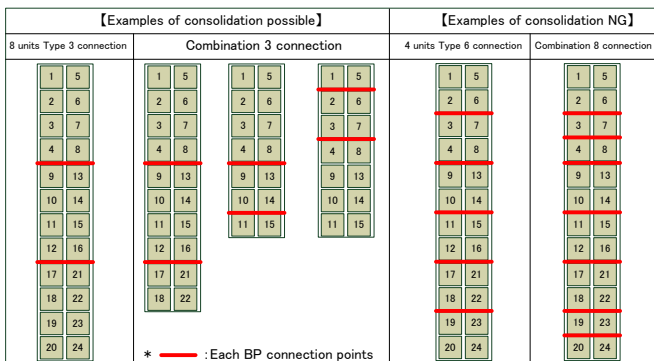

· Following diagram is shown redundant output with analog output module.

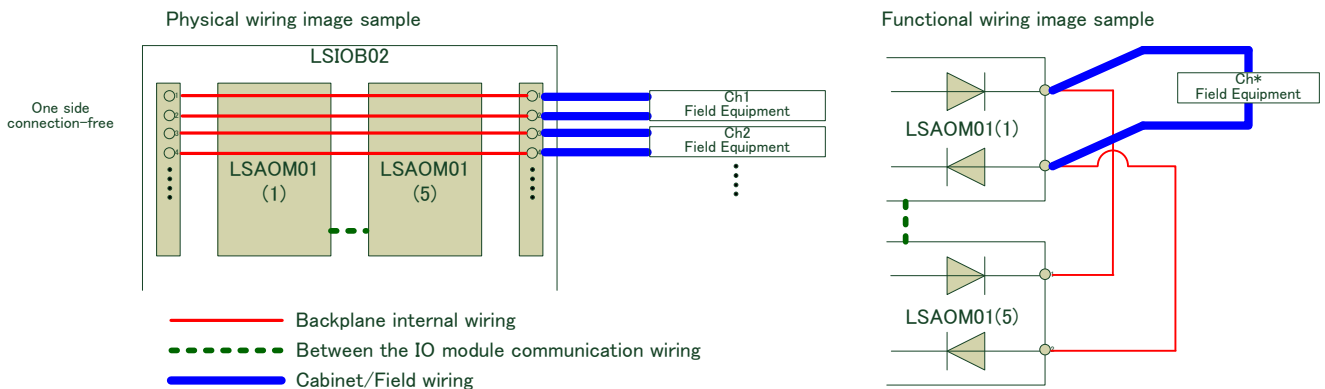

LSIOB02-2 I/O module backplane

Redundant Supports 2 modules

■ Block diagram

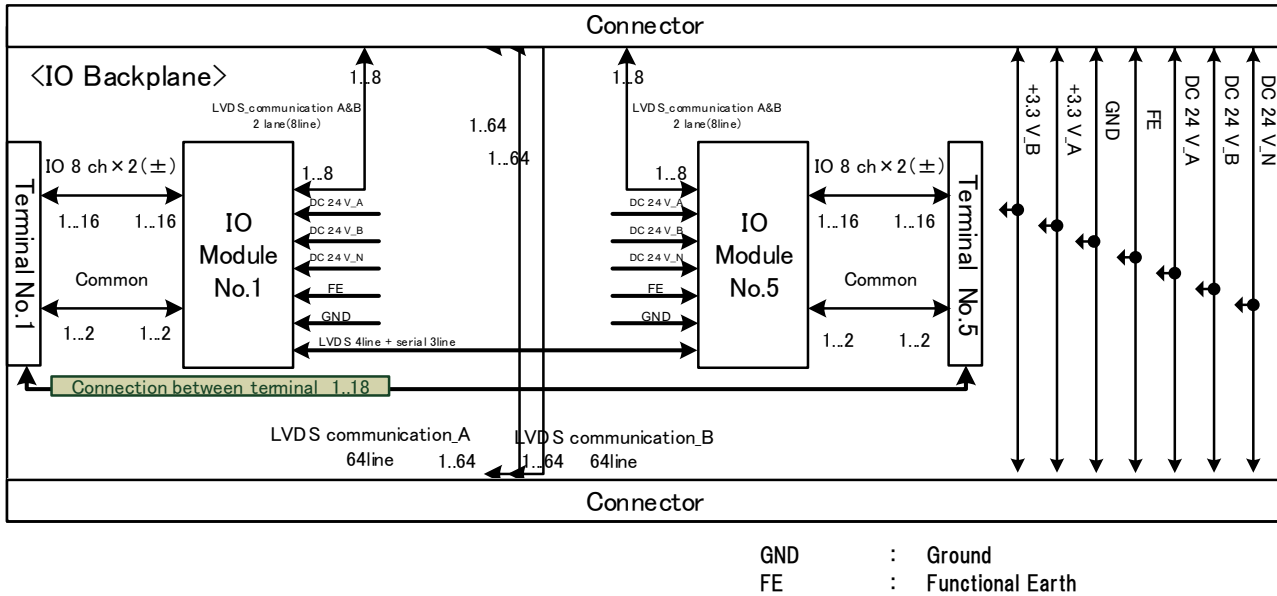

When using, please read the instruction manual attached to the product carefully and use it properly.

This catalog may not be distributed or reproduced in whole or in part without permission.

Please be aware that due to product improvements and modifications, the product description in this catalog may differ in certain respects from the actual product.

DIASYS Netmation/DIASYS Netmation4S is a registered trademark of Mitsubishi Heavy Industries, Ltd.

The service names and product names of other companies described in this catalog are the trademarks or registered trademarks of each company.