

LSRLTS-D001 FXtoLS Adapter (Type10)

Built-in varistor for DOM01

Summary



- * Summary : Conversion adapter for mounting D-Ring I/O module on FX terminal block
- * I/O terminal connection : Channel 8 points (CH1± to CH8±) with built-in anti-surge varistors
- * Supported modules : (FX-I/O module)
FXDOM01/D, FXDOT01

(D-Ring I/O module)
LSDOM01-1-R
- * Power supply : DC 24 V (Connector connection between the FX terminal block)

Specifications

ITEM		SPECIFICATION
Power Specifications	Rated voltage	DC 24 V ±20% (Connector connection between the FX terminal block)
	Redundancy method	Independent two-line power supply
Communication method		LVDS
FX terminal block connector	Number of channels	1
	Rated voltage	DC 300 V / AC 264 V
	Rated current	2A
I/O module connector	Number of channels	1
LVDS communication connector	Number of channels	2
PE connector	Number of channels	1
I/O channel		8 ch input-output
Supported module	FX-I/O module	FXDOM01/D, FXDOT01
	D-Ring I/O module	LSDOM01-1-R
Environmental condition	Module ambient temperature	(Operating) 0 to 55°C (Storage) -40 to 85°C
	Module ambient humidity	(Operating / Storage) 5 to 95% RH (No condensation)
vibration		3.5 mm @ 5 Hz to 8.4 Hz 1 G @ 8.4 Hz to 150 Hz
Shock		15 G 11 ms
Weight		0.17 kg
Dimensions		55 mm (D) x 94 mm (H) x 46.5 mm (W) (Except projection)
Standard/Directive		IEC 61131-2 : 2017, RoHS directive

(Caution) When replacing from a FX-I/O module to a D-Ring I/O module, carefully check the specifications of the corresponding D-Ring I/O module

LSRLTS-D001 FXtoLS Adapter (Type10)

Built-in varistor for DOM01

■ Block diagram

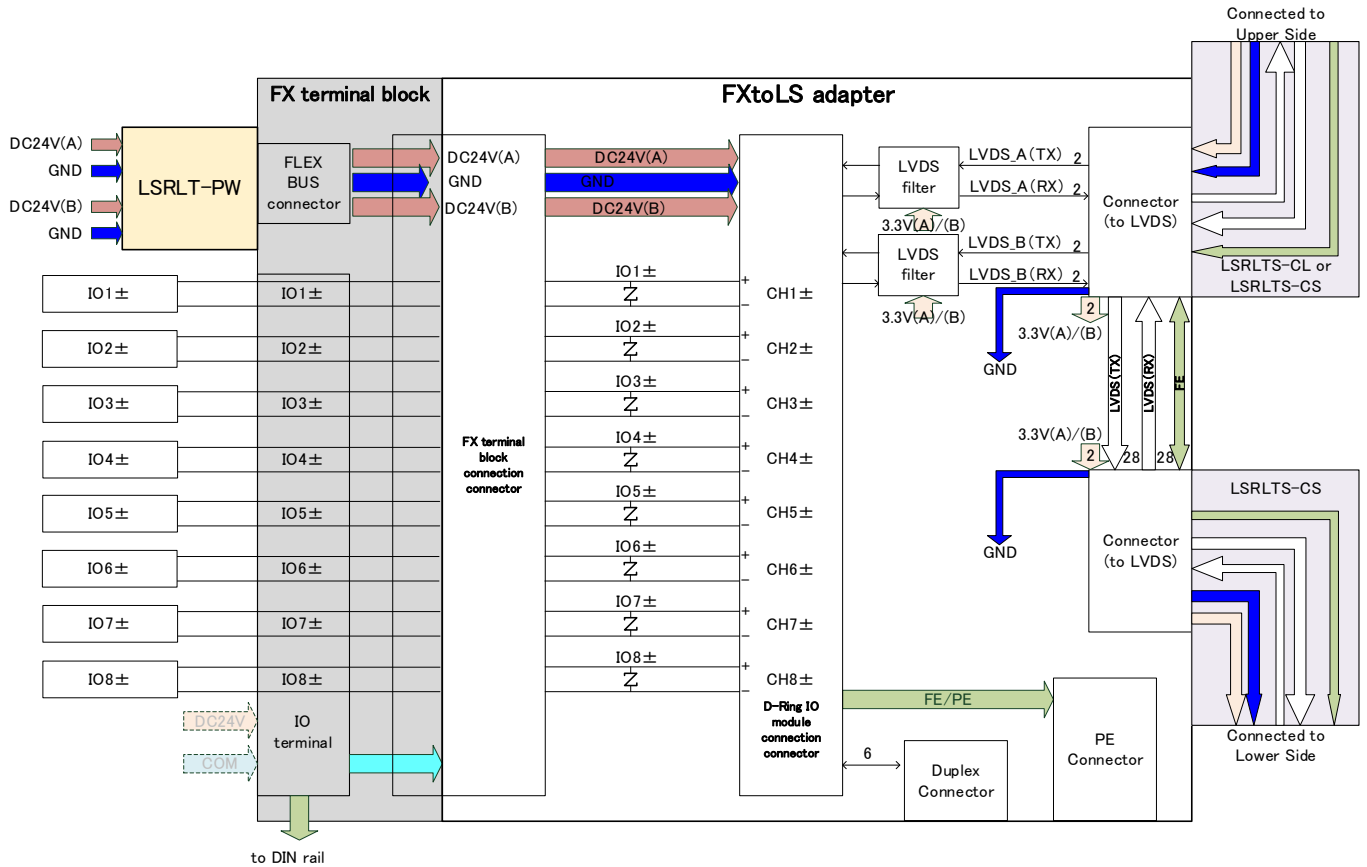

LVDS : Low Voltage Differential Signaling
 GND : Ground
 COM : Common
 FE : Functional Earth
 PE : Protective Earth

When using, please read the instruction manual attached to the product carefully and use it properly.

This catalog may not be distributed or reproduced in whole or in part without permission.

Please be aware that due to product improvements and modifications, the product description in this catalog may differ in certain respects from the actual product.

DIASYS Netmation/DIASYS Netmation4S is a registered trademark of Mitsubishi Heavy Industries, Ltd.

The service names and product names of other companies described in this catalog are the trademarks or registered trademarks of each company.